

---

---

## Lab 4. SERIES AND PARALLEL RESISTORS

### 3.1. Problem

- How do you measure resistance, voltage, and current in a resistor?
- How are these quantities related?
- What is the difference between a series circuit and a parallel circuit?

### 3.2. Equipment

digital multimeter with ohmmeter, voltmeter, and ammeter functions; two different resistors; wires (at least five); alligator clips; battery or other DC power supply

### 3.3. Background

The primary purpose of this lab is to investigate the relationship between potential, resistance, and current in simple direct current (DC) circuits. For a given value of the current, the potential difference across the material depends on the resistance. This relationship is known as Ohm's law and is given by the equation

$$V = IR$$

where  $V$  is the potential drop across the resistor,  $I$  is the current through the resistor, and  $R$  is the resistance of the resistor. In both SI and common American usage, potential is measured in volts (V), current in amperes (A), and resistance in ohms ( $\Omega$ ).

In this lab you will measure all of these quantities in different types of circuits. There are three common types of electrical meters. A **voltmeter** measures the electrical *potential* difference (voltage) across two points in a circuit. An **ammeter** measures the *current* through a wire or an electrical component in a circuit. An **ohmmeter** measures the *resistance* of an electrical component or between two points in a circuit. A **multimeter** can do all of these measurements.

You will also learn to read simple circuit diagrams in this lab. A list of common circuit symbols with their meanings is printed inside the back cover of this lab manual.

#### USING A DIGITAL MULTIMETER

Most digital multimeters are able to protect themselves from being damaged if you choose the wrong range or connect the wires to the terminals in the wrong order. However, the multimeter can easily be damaged by connecting the meter in the ammeter mode between two wires at different voltages. Please take care of your multimeter and avoid overloading it. **If you subject the meter to excessive voltages or currents, you may blow a fuse. Always disconnect the power before inserting or changing a meter in a circuit.** Make sure the circuit is set up correctly and the meter is off before reconnecting the power. Here are the general rules for using the multimeter in each mode:

## 1. Resistance

**The best way to measure the resistance of an electrical component is to remove the component from the circuit.** If this is not feasible, make sure that all power sources in the circuit are disconnected. Before you use the meter, select the correct function ( $\Omega$ ). Turn the ohmmeter on, then touch both ends of the probes together. You should get a zero reading.

To measure the resistance of a component, touch the two ends of the component with the probes. See Figure 1.

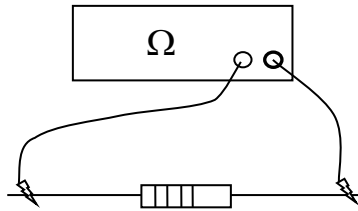

Figure 1. Measuring the resistance of a resistor.

First select the highest range (farthest right button), then reduce the range to get the most precise reading. If the reading is “1.”, that means you are off the scale and should change to a higher range.

**Never measure the resistance between two points that are at two different voltages, such as the terminals of a battery.** If you do, the ohmmeter will be overloaded. (This is why you should take the component out of the circuit first.) Finally, do not keep your multimeter in the ohmmeter mode when not in use. The small internal current is powered by an internal battery that can lose its charge if kept on for a long time.

## 2. Voltage

A voltmeter measures the difference in electrical potential between two different positions in an electrical circuit. Therefore, **to measure the voltage touch two different positions in the circuit with two probes**, as shown in Figure 2. You measure the voltage *across* an electric component or system of components, i.e., the meter is connected in *parallel* with the component.

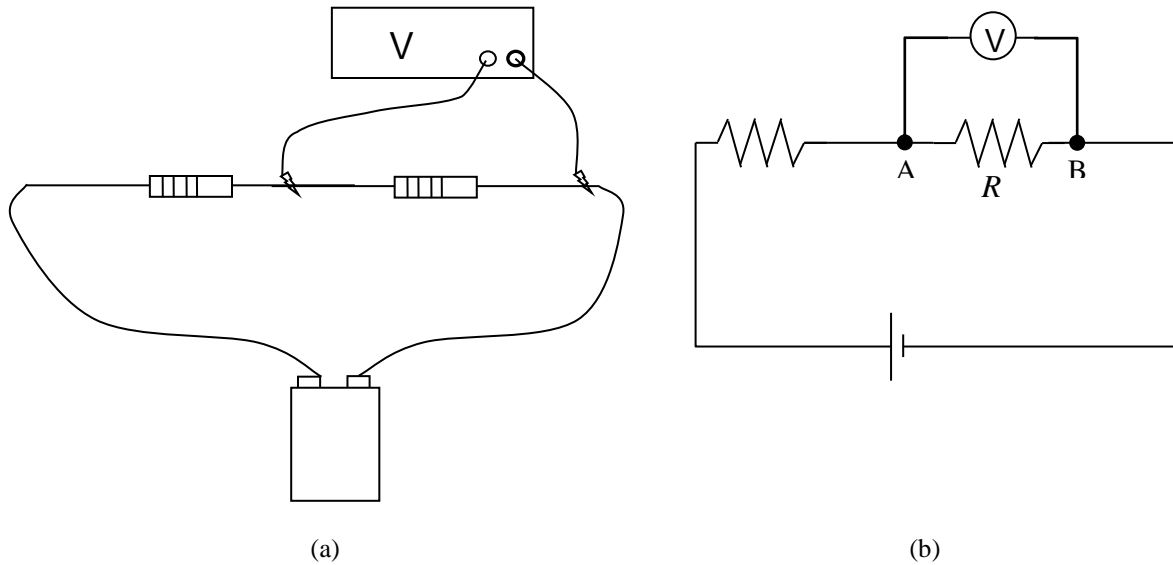

Figure 2. Measuring the voltage,  $V$ , across a resistor  $R$  with a voltmeter (symbol  $V$ ). (a) Representative drawing; (b) the same in circuit symbols.

The positive (red) probe must be closer to the positive power terminal in the circuit. The negative (black) probe must be closer to the negative terminal. This is called the *polarity*. If you connect the probes backwards, the voltage readout will be negative. This is generally not a problem as long as you understand what is going on. As when measuring resistance, start with the highest range and work your way down to get the most precise reading.

### 3. Current

Current is the flow of electrical charge *through* a wire or electrical component at a certain point in a circuit. **To measure current, break the circuit before or after the component and insert the ammeter into the break, i.e., in series.** See Figure 3. One probe of the ammeter connects to one end of the break and the other probe connects to the other end of the

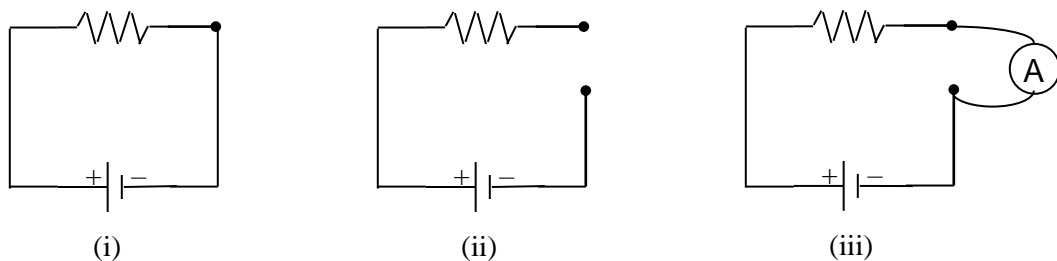

Figure 3. To measure the current through the resistor and circuit: (i) choose a point at which to measure the current; (ii) break the circuit at that point; then (iii) insert the ammeter, taking care to use the proper polarity.

break.

When using an ammeter, observe the following precautions:

- (1) *Never connect an ammeter between two points in a circuit that are at two different potentials.* If you do, you will blow a fuse. The two ends of the break in the circuit of Figure 3 are at the same potential. If in doubt, check the break with a voltmeter (it should read 0 V) before you switch to ammeter mode.
- (2) *Do not exceed the range of the ammeter.* Start with the largest range and then choose smaller ranges to obtain more precise measurements.
- (3) Double-check that the circuit is set up correctly before inserting the ammeter. It is very easy to blow the fuse in the ammeter; please avoid doing so!

If the ammeter always reads zero current when you expect it to be measuring something, consult your instructor. The fuse may be blown (by someone not following the precautions above).

### 3.4. Measurements

#### A. RESISTANCE

1. Determine the theoretical resistance of your two resistors based on their color codes (see below). Record these in Table 1. Make sure you remember which resistor has which resistance.

#### Resistor Codes

Read the color bands on the resistor from left to right, starting with the one nearest an edge of the resistor.

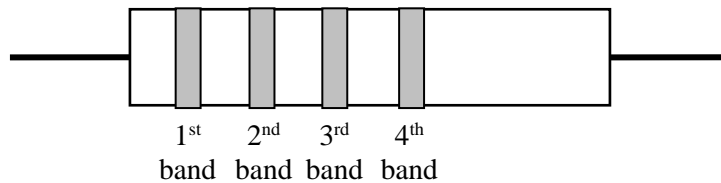

Each color corresponds to a given value:

<u>Color</u>	<u>Value</u>	<u>Color</u>	<u>Value</u>
Black	0	Gold	5%
Brown	1	Silver	10%
Red	2	Colorless	20%
Orange	3		
Yellow	4		
Green	5		
Blue	6		
Violet	7		
Gray	8		
White	9		

The first and second bands give the first two digits of the resistance. The third band gives the number of zeros after these two digits. The fourth band gives the tolerance or precision of the coded resistance.

For example: Brown-Orange-Red-Gold =  $1300 \pm 5\% = 1300 \Omega \pm 65 \Omega$ .

Thus a resistor with the color code Brown-Orange-Red-Gold will have a resistance within the range  $1235 \Omega$  to  $1365 \Omega$ . The actual value must be found by measurement.

- Set the multimeter on the ohmmeter setting. Plug in two probes (wires with alligator clips) and make sure you get a “zero” reading when you touch the probes together.



- Measure the resistance of each resistor with the multimeter and record your values in Table 1. Remember to include the units.

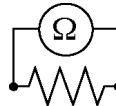

- For the “theoretical” resistances of the individual resistors, use the values from their codes.

- Now connect the two resistors together in series, either with an alligator clip or on a circuit board, and measure the resistance of the pair. Record this.

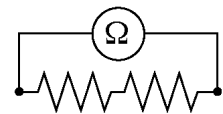

- Connect the resistors together in parallel and measure the resistance of the pair. Record this also.

- For the “theoretical” resistance of the combinations, use the measured values of the individual resistances and the rules for combining resistors.

8. For each case, calculate the percent difference between the measured value and the theoretical value. This is  $\frac{\text{measured value} - \text{theoretical value}}{\text{theoretical value}} \cdot 100\%$ .

	Theoretical Resistance	Measured Resistance	% Difference
R <sub>1</sub>			
R <sub>2</sub>			
Series			
Parallel			

### B. VOLTAGE ACROSS RESISTORS IN SERIES

A circuit is called a *series circuit* if all of the circuit components are in a single loop, so that there is only one path for the electric current to follow.

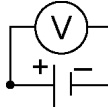
1. First, measure the voltage between the positive and negative terminals of your power supply. Record this value as the total voltage (in the third row of Table 2). 
2. Next, set up the circuit shown in Figure 4 below, as follows:
  - a) If you are using the central power supply, plug a red wire into the positive terminal. If you are using a circuit board, simply insert a battery into one of the battery slots. If you are using wires only, clip one wire to each terminal of the battery holder.
  - b) Connect the positive terminal to one end of resistor R<sub>1</sub>. (It doesn't matter which resistor you choose to be R<sub>1</sub>.)
  - c) Attach the other end of resistor R<sub>1</sub> to one end of resistor R<sub>2</sub> using another wire, by linked coils on the circuit board, or an alligator clip.
  - d) Connect the other end of R<sub>2</sub> to the negative terminal of the power supply or battery.

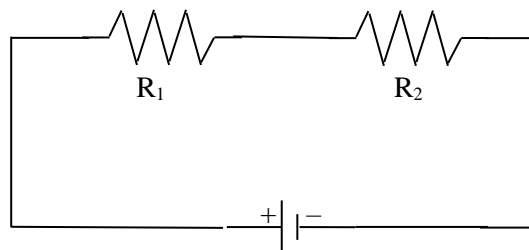
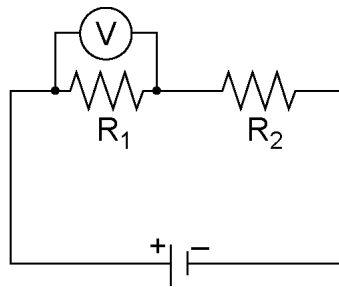
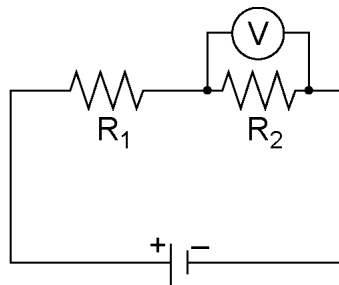

Figure 4. A simple circuit using two resistors in series. Note that this is the same circuit as in Figure 2, without the voltmeter.

3. Once the circuit is connected (including both resistors), set the multimeter on volts and measure the voltage across  $R_1$ . (See Figure 2.) Record this value in Table 2. (Don't forget the units!)



4. Without changing the resistors in the circuit, measure the voltage across  $R_2$  and record this value. (Don't forget the units!)



### C. CURRENT IN A SERIES CIRCUIT

1. Disconnect the multimeter and change it to ammeter mode. Disconnect the power to the circuit.
2. Break the circuit between the positive power outlet and resistor  $R_1$ . (See Figure 3.) Connect one end of the ammeter to the power supply and the other end to the resistor. Reconnect the power and measure the current going into  $R_1$ . Record this value in Table 2. (Don't forget the units!)

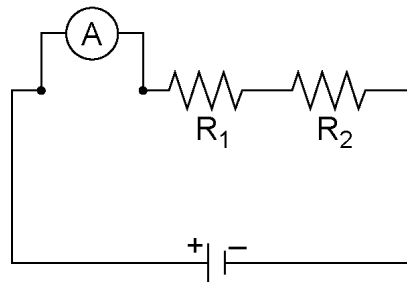

- Remove the ammeter, reconnect the circuit, and then break the circuit between  $R_1$  and  $R_2$ . Measure the current through this point. Record this value as the current going into  $R_2$ . (Don't forget the units!)

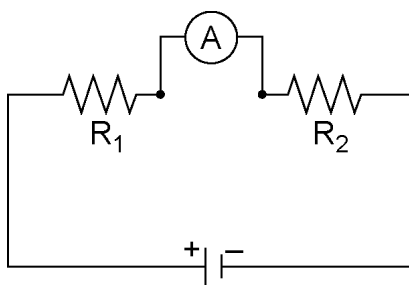

- For completeness, restore the circuit again and then break the circuit at a point between  $R_2$  and the negative power outlet. Measure the current at this point. Record this in the "Combined" row. (Don't forget the units!)

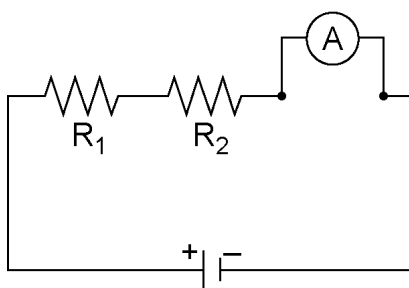

- Calculate the resistance of each resistor and the entire circuit using Ohm's law and your measured values of the voltage and current. Record the results of your calculations in the "Calculated Resistance" column of Table 2. (Don't forget the units!)
- Copy the entire column of measured values of the resistors from Table 1 into the "Measured Resistance" column of Table 2.
- Calculate the percent difference between the calculated values and the measured values of resistance in each case, using the measured values as the "true" values. Enter in the "% Difference" column of Table 2.

**Table 2: Series circuit**

	Voltage	Current	Calculated Resistance	Measured Resistance	% Difference
$R_1$					
$R_2$					
Combined					



### D. CURRENT AND VOLTAGE IN A PARALLEL CIRCUIT

A circuit is called a *parallel circuit* when the circuit splits at one or more points, providing more than one path for the current to follow.

1. Disconnect the multimeter and take apart your series circuit.
2. Change your circuit to a parallel circuit as shown in Figure 5 below. There are many different ways to connect the components that yield this connectivity. If you are not sure that you have set up the circuit correctly, check with your instructor.

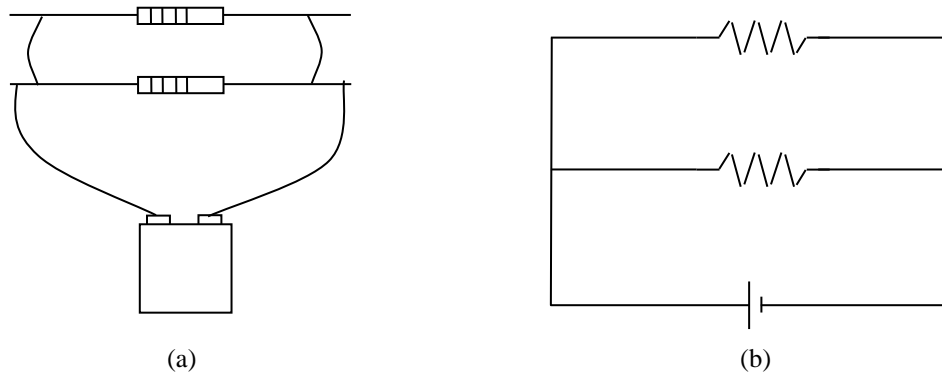
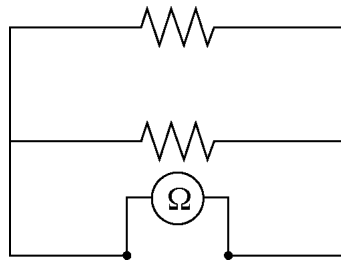
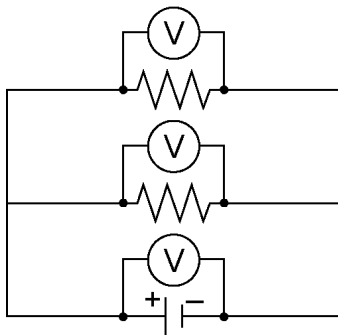

Figure 5. A circuit containing two resistors in parallel. (a) Schematic drawing; (b) the same in circuit symbols.

3. Begin with measuring resistance. Disconnect the power and measure the total resistance of the circuit by connecting the ohmmeter to the two wires that connected the circuit to the power supply. Record this value in the “Measured Resistance” column of Table 3. (Don’t forget the units!) Also copy the resistances of the individual resistors from Table 1 into the “Measured Resistance” column of Table 3.



4. Next, measure voltage. Reconnect the power and measure the potential across each resistor while they are in the parallel circuit. Also measure the voltage across the power supply while the resistors are in the circuit. Record these values in the “Voltage” column of Table 3. (Don’t forget the units!)



5. Finally, measure current. Break the circuit at one terminal of the power supply and connect the ammeter (as in *a*) to measure the total current entering or leaving the circuit. Restore the circuit, then measure the current through the first resistor by breaking the circuit at the single wire connected to  $R_1$  and connecting the ammeter in series as in *b*. Repeat for  $R_2$  as in *c*. (You may need to rearrange the wires so that the ammeter measures only the current flowing from the resistor you are measuring.) You should get three different values. Record these values in Table 3. (Don’t forget the units!)

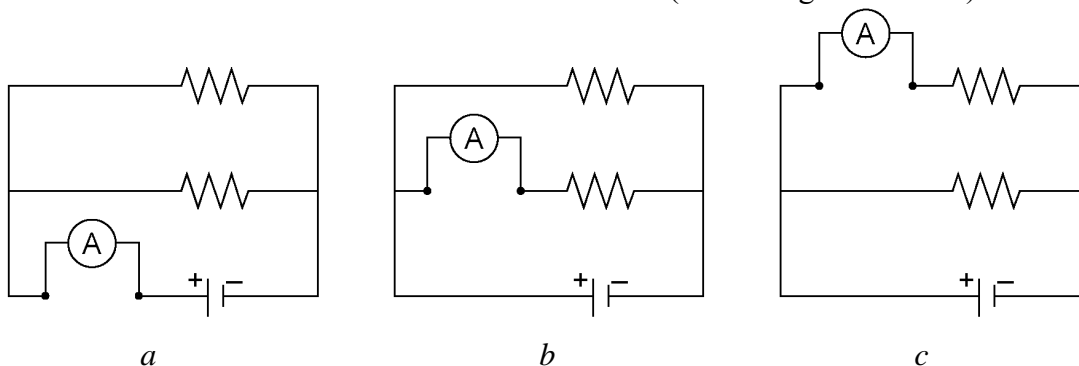

6. Calculate the resistance of each resistor and the completed circuit using Ohm’s Law and your measured values of voltage and current. Find the percent difference between the calculated resistance and the measured resistance in each case, again using the measured values as the “true” values. Enter in the “Calculated Resistance” column in Table 3. (Don’t forget the units!)

**Table 3: Parallel circuit**

	Voltage	Current	Calculated Resistance	Measured Resistance	% Difference
$R_1$					
$R_2$					
Combined					